

STREACOM™
FIC EVO
USER GUIDE

Page

2.....	Index, Foreword
3.....	Product Overview
4.....	Preparation for Assembly
5.....	Installing the Motherboard
6.....	Installing the ODD and HDD(s)
7.....	Replacing the HDD/ODD Cage and Top Panel

Foreword

Thank you for your purchase of this Streacom product, every care has been taken to ensure that it meets with the high standards that we have set for ourselves.

Should you have any questions that are not covered in this user guide, support can be offered via email through our website at www.streacom.com

We sincerely hope that you enjoy using our product!



Specification

Chassis Material	Aluminum
Available Colours	Silver / Black - sandblast finish
Motherboard Compatibility	Mini ITX
HDD Drive Support	3 x 2.5" (depending on components installed)
ODD Drive Support	Slot loading drive, universal eject button
Cooling Method	1 x 40x40x10mm or 1 x 60x60x10mm fan (not Included)
Dimensions	197 × 197 × 77mm (L×W×H) + 3mm feet
Power Supply Support	NanoPSU & external DC adapter (not included)
IR Solution	MCE compatible IR receiver & remote (not included)
Net Weight	1.6KG

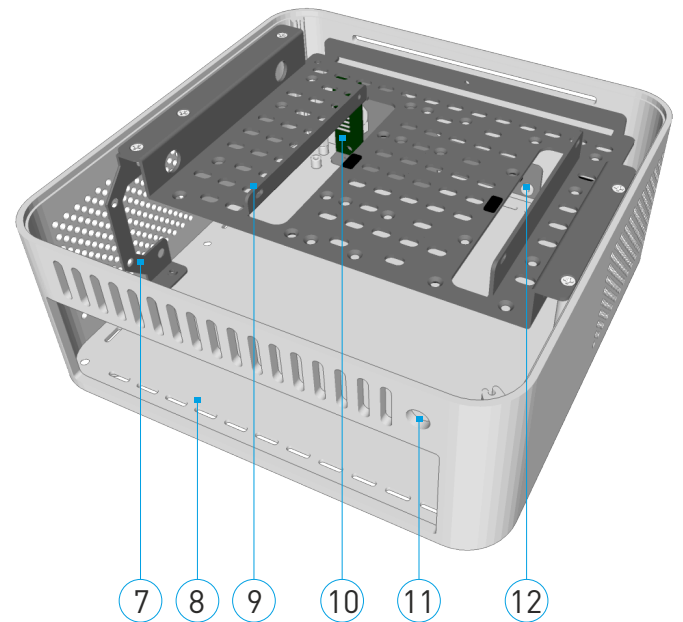
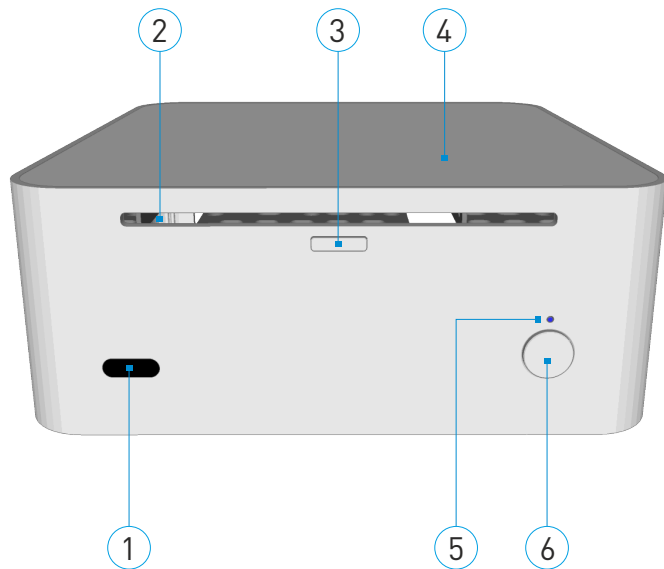

Key Features

- 1..... IR Receiver Window
- 2..... ODD Loading Slot
- 3..... ODD Eject Button
- 4..... Top Panel
- 5..... Power LED
- 6..... Power Button
- 7..... 40 or 60mm Fan Bracket (Fan not Included)
- 8..... IO Shield Opening
- 9..... HDD / ODD Mounting Cage
- 10.... Power Button PCB
- 11.... DC Power Jack Hole
- 12.... IR Receiver Mounting (IRRC Not Included)

Removing the Top Panel

The top panel is held in place by 2 long screws that are accessed from the bottom of the case. Turn the chassis upside down and remove the 2 screws from either side. The top panel can now be lifted off the chassis.

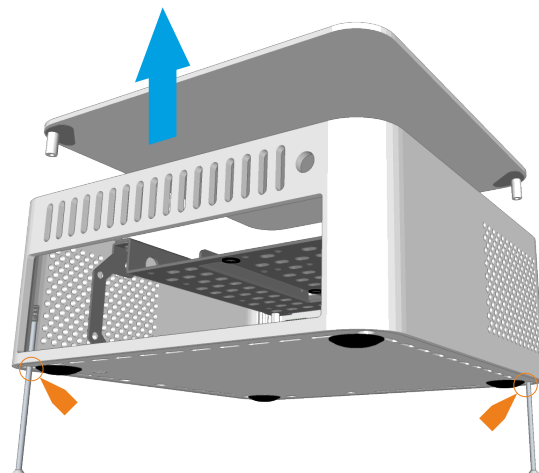
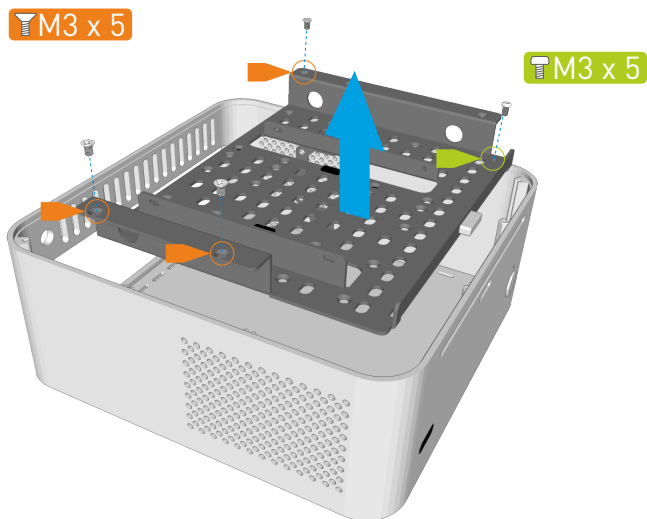

Removing the HDD/ODD Cage

The HDD/ODD cage is held in place by 4 screws, which are all accessible from the top of the cage. Remove all 4 screws and lift the cage out of the chassis.

Fitting Cooling Fan & IRRC Module (Optional)

The F1C Evo can accommodate a 40 or 60mm fan (60mm may interfere with fitting of 2.5" HD, see HDD installation). The fan cage is packed with the other screws and accessories. Fit your purchased fan with 2 screws as shown (Depending on 40 or 60mm). Fit the fan assembly to the case using a single screw from under the chassis.

The IRRC module can be installed into the position shown (in red) using 2 screws supplied.

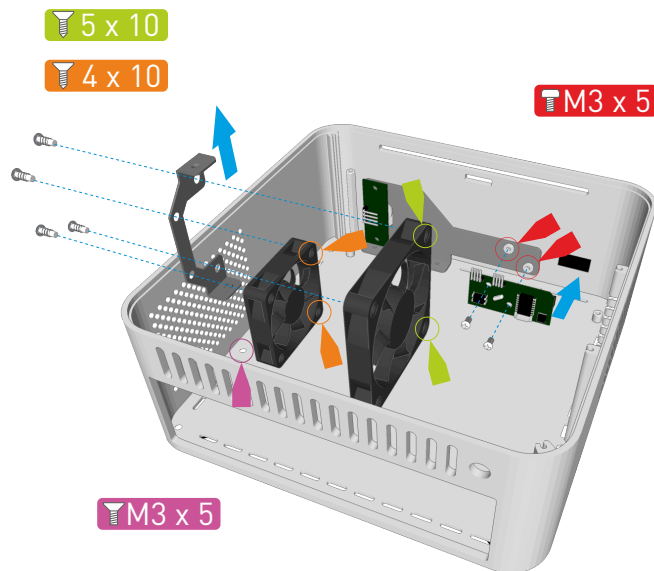

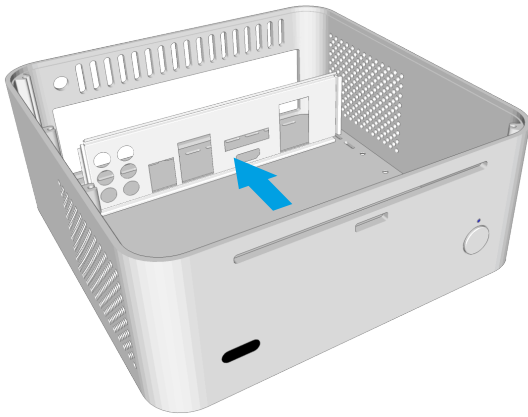

Installing the Motherboard

Locate the I/O shield that is supplied with your motherboard and firmly push it in place. Ensure that it clicks in place fully otherwise the motherboard will be difficult to fit.

Carefully lower the motherboard into the chassis, with the I/O port side leading so that the ports can fit into the I/O shield.

When the motherboard is correctly in position, fix it to the chassis stand-offs using the screws provided. Ensure that all the holes correctly align before fully tightening the screws.

 M3 x 4

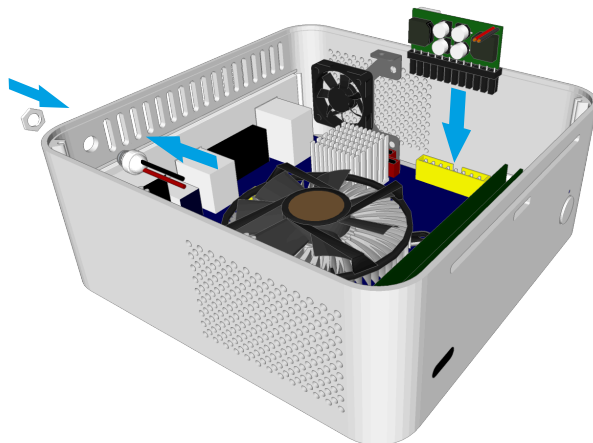
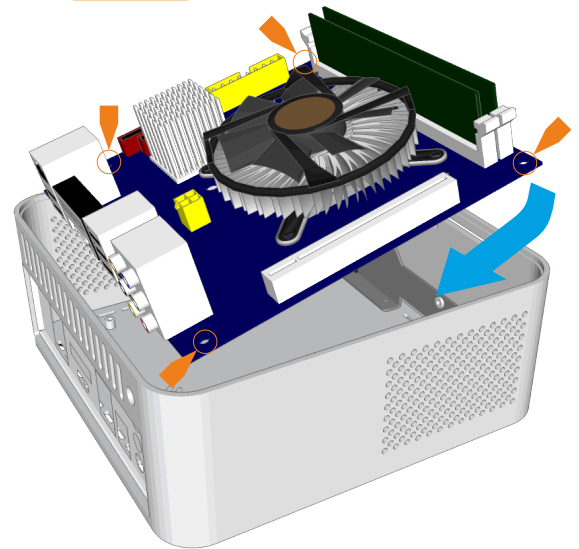

Connect NanoPSU & Other Cables

With the motherboard in place, you can now connect the PSU and any other internal connectors such as the power button switch. You should also connect the SATA cables in preparation for installing the HDD/ODD cage assembly.

Installing the HD and OD Drives

Depending on the type of components fitted, you can install a maximum of 3 x 2.5" hard drives and 1 slot loading optical drive.

If you are using a low profile CPU cooler, up to 2 hard drives can be fitted under the cage and should be installed prior to fitting the optical drive.

If you intend to fit 2 drives under the optical drive, use positions B & C. If fitting just one drive, use position A.

Rubber pads can be affixed to the mounting holes that will be used in order to reduce vibration (if SSD's are not used).

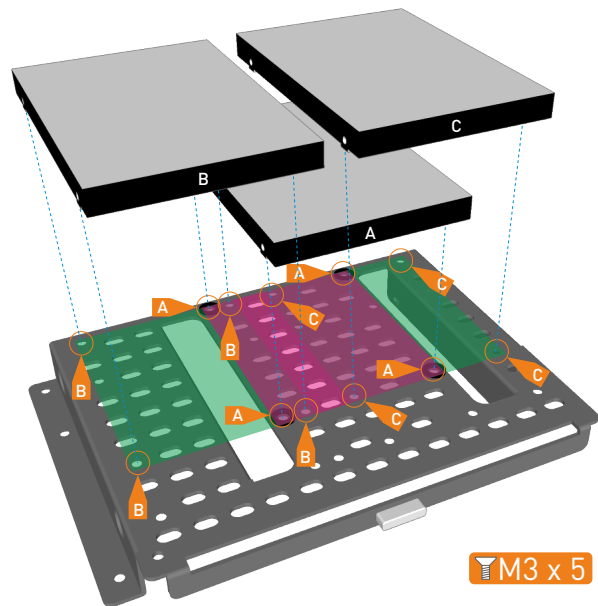

Before fitting the slot loading drive, affix a self adhesive rubber pad to the drives eject button (included in the accessory bag). Mount the slot loading drive using 4 screws, 2 either side, and adjust its position to ensure correct operation of the eject button. With left side eject buttons, 2 pads may be required.

The primary 2.5" hard drive can be mounted vertically using 2 screws. Ensure that the HDD connectors are facing toward the back of the chassis. Please note that if you are using a 60mm fan, a 90 degree power/ sata connector must be used to avoid conflict with the fan.

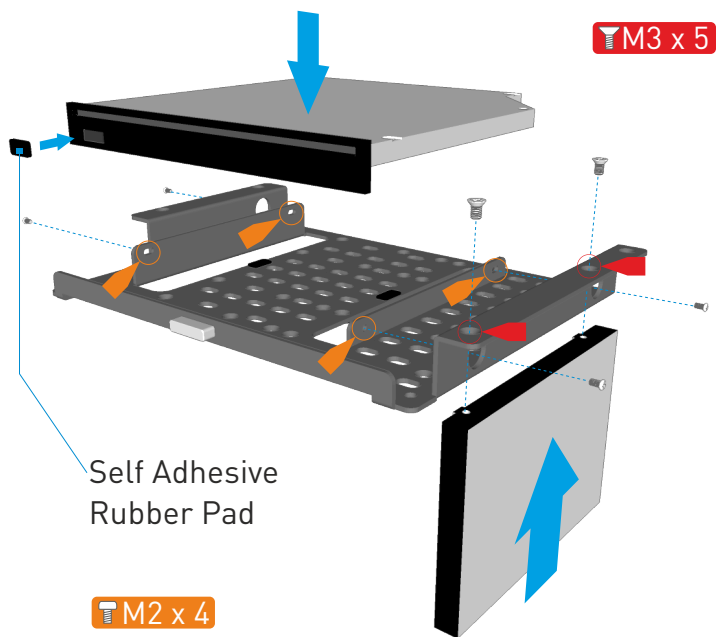

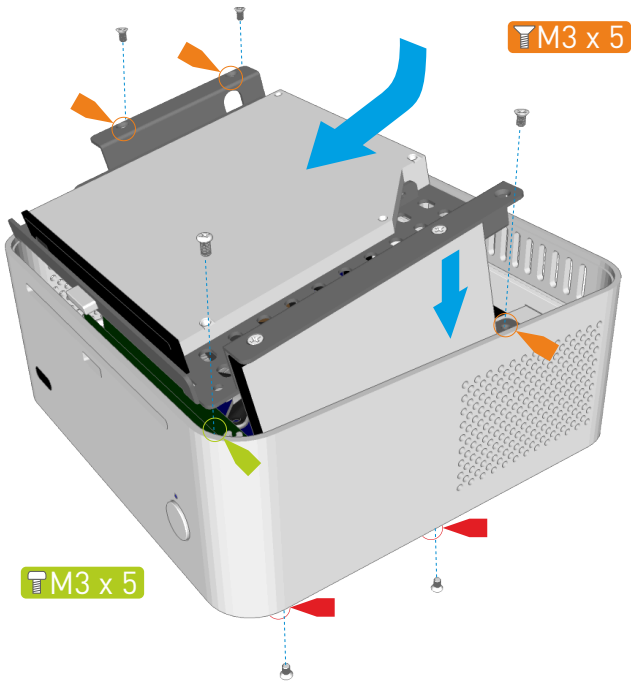

Replace the HDD/ODD Cage

With the HDD/ODD installed, the cage can now be replaced into the chassis. Carefully lower the assembly ensuring cables are routed correctly and that the ODD eject button clears the front of the chassis and slots into the hole.

The HDD/ODD cage can now be secured to the chassis using 6 screws in total, 4 at the top and 2 from underneath. Note that the 2 screw underneath fix to the 2.5" hard drive, so ensure the correct screws are used.

Replace the Top Panel

With all the components installed, all that remains is to replace the top panel and secure it in place with the 2 long screws from underneath the chassis.

When replacing the top panel, ensure the correct orientation as the 2 long securing screws should match up with the nuts in the top panel.

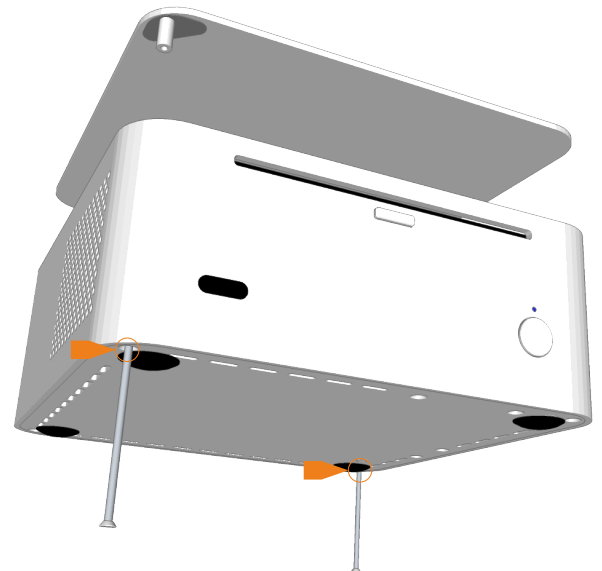

STREACOM™

Melbournestraat 56,
3047 BJ Rotterdam,
The Netherlands
www.streacom.com

V1.12.09