

***STREACOM™***



***FC9α***

Page	Contents
2 .....	Index, Message, Introduction
3 .....	Product Overview
4 .....	Preparation for Assembly
5 - 6 .....	Installing the Motherboard
7 - 8 .....	Installing the CPU Cooler
9.....	Installing PSU & Other Accessories
10 .....	Wiring Diagram
11 .....	Installing Expansion Card (Optional)
12-14 .....	Installing Drives
15 .....	Final Adjustments, Replacing the Top Panel

### IMPORTANT NOTICE

Passively cooled products can get hot to the touch, especially when systems are running at high loads for extended periods. This is a normal part of their operation and they have been tested to run safely under these conditions. Please take their operational temperature into consideration when positioning and handling.

### COPYRIGHT NOTICE

Copyright © 2014 Streamcom. All Rights Reserved. No part of this publication may be reproduced, stored in a retrieval system, or transmitted, in any form or in any means – by electronic, mechanical, photocopying, recording or otherwise – without prior written permission. All trademarks and registered trademarks in this publication are the property of their respective owners. Streamcom is a registered trademark.

## A Message from the Streamcom Team

“ Thank you for choosing Streamcom! In a market dominated by generic and uninspired products, we are on a mission to break the mold, not only of design, but materials and finish. This is a value that is not easily conveyed in an industry preoccupied with specs and numbers, so your choice shows an appreciation and understanding of what makes our products different, and we sincerely thank you for that.



Every care has been taken to ensure that this product meets the highest quality and standards we have defined. If anything about this product falls short of your expectations or you have any questions that are not covered in this user guide, please contact us online at [www.streamcom.com/contact](http://www.streamcom.com/contact). We respond to every question received and your feedback is a critical part of our ongoing product development and refinement.

From everyone at Streamcom, we hope that you enjoy using our product!

## Introduction to Assembling Your Case

It's not rocket science, but Streamcom cases can be a little challenging to assemble at first because of the non traditional design and the materials used. Passive cooled cases have an added layer of complexity because of the heatpipe assembly/hardware requirements, so please take the time to read the user guide and become familiar with the components and assembly procedure. Additional information is also available on our website 'system build guide' page, and of course from our support staff.

Below is a quick explanation of the different screws used in the assembly, and how they will be referred to throughout the guide. Screws are defined by head type, e.g. 'countersunk' and by thread/size e.g. M3x5, and will be labeled with all that information, e.g. CS-M3x5

-  Pan Head Screw (PH)
-  Hex Cheese Head Screw (HC)
-  Countersunk Screw (CS)
-  Thin Cheese Head Screw (TC)
-  Thumb Screw (TS)

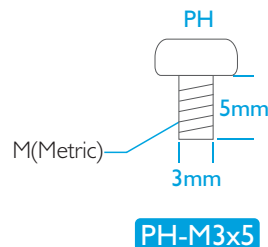

### Also included in the kit.....

1 x Lower CPU Mount, 2 x Upper CPU Mount, 3 x Heatsink Connectors, 4 x Heatpipes, 4 x Spring-loaded Screws & Nuts, 1 x Allen Key, 2 x Thermal Paste Tubes, Silicon Rubber Pads, Double Sided Adhesive Pads.

### Tools you will need.....

Philips Screwdriver

## Specification

Construction Material	Premium Grade Aluminum (6063)
Available Colours	Silver / Black - Anodized & Sandblasted Finish
Motherboard Compatibility	Micro-ATX and Mini-ITX (Heatpipe Compatibility Dependent)
Hard Drive Support	Minimum 1 x 3.5" + 2 x 2.5", Maximum 3 x 3.5" + 3 x 2.5" (Hardware Dependent)
Optical Drive Support	1 x Slot Loading Optical Drive, Universal Eject Button*
Cooling Method	Passive Convection/Radiation - 4 x Heatpipe Direct Touch (65W Recommended, 87 Max)
Side Ports	2 x USB 3.0, Left & Right Side (Optional USB2.0 Conversion Cable**)
Expansion Slot	3 x Low Profile Expansion Cards (Max Length, 156mm)
Dimensions	348 x 290 x 110mm (WxDxH, Including Feet)
Power Supply Support	NanoPSU (External AC Adapter + Internal DC to DC)** or ZeroFlex240 (Fanless Internal PSU)**
IR Solution	IRRC or FLIRC IR Solutions**
Net Weight	4.4KG (Excluding Heatpipe Assembly)

\* FC9 Optical Version Only

\*\* Not Supplied With Case

## Key Features

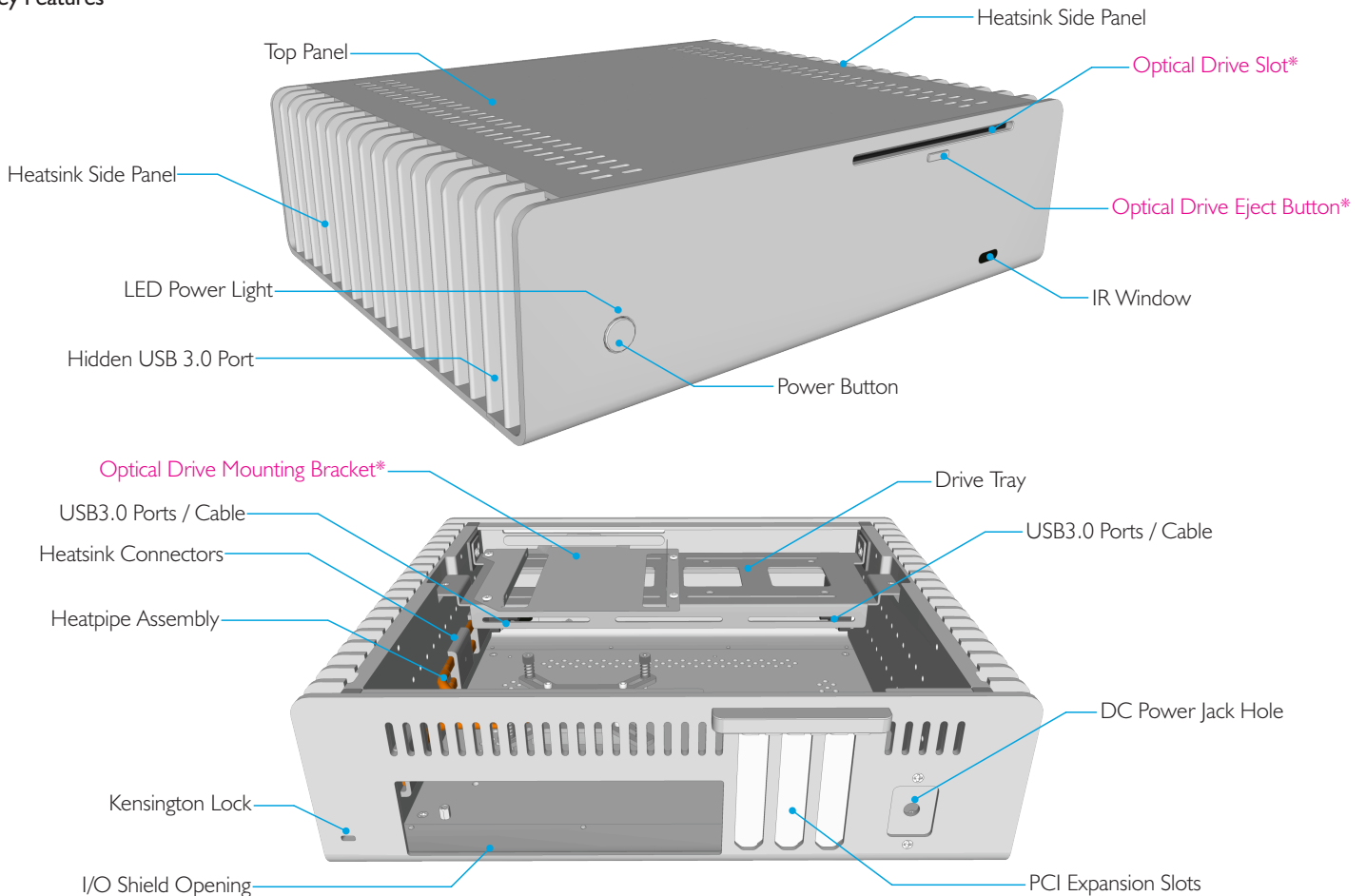

## Removing the Top Panel

The top panel is held in place by a total of 4 screws, 2 from each side of the case which are accessible between the fins of the heatsink.

Remove all 4 screws and lift the top panel away from the case. There is a cutout either side of the case to assist with lifting the top panel.

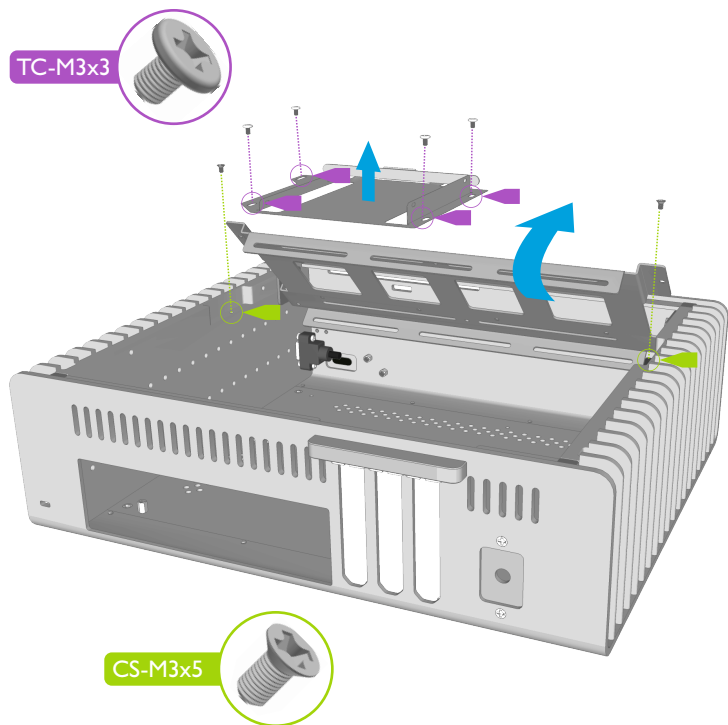
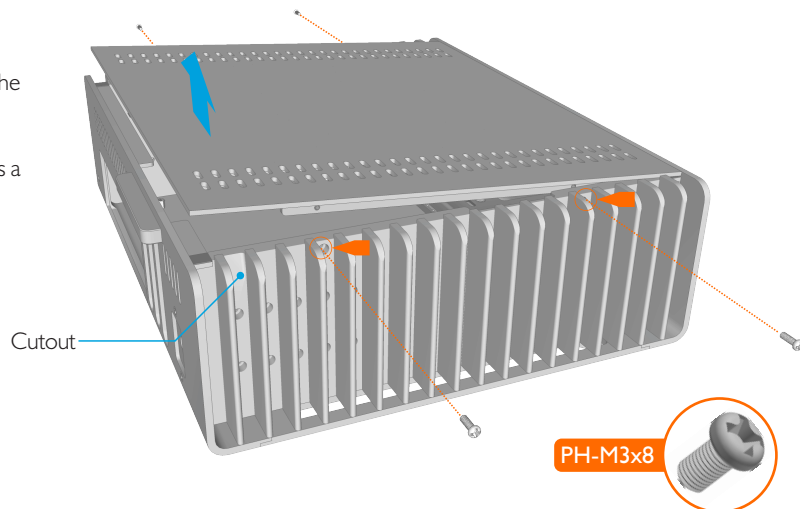

## Open the Drive Tray

The drive tray has a swivel design that rotates upwards and towards the front of the case. It is locked in place by 2 screws, 1 either side of the tray. Remove these 2 screws and rotate the tray until it makes contact with the front of the case. This will allow you full clearance inside the case so that you can easily install the components.

If you have the Optical version of the FC9, you should also remove the optical drive mounting bracket by removing the additional 4 screws as shown.

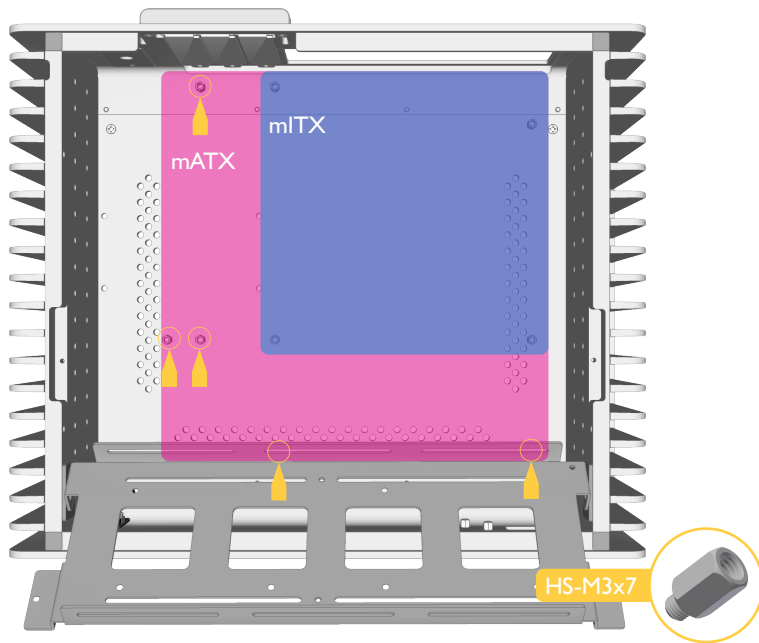

### Preparation for Installing the Motherboard

The FC9 can accommodate a Micro-ATX or Mini-ITX motherboard and depending on which one is used, the appropriate stand-offs should be fitted to the bottom panel of the case. Note that the Mini-ITX stand-offs are already fitted to the case as they are common to all motherboards. The type of motherboard used will also determine the choice of other internal components such as additional 3.5" hard drives and optional internal PSU. Check your motherboard hole locations and fit the appropriate stand-offs in the corresponding position on the bottom panel. The stand-offs can be hand tightened in place.

### Installing the I/O Shield

Locate the I/O shield supplied with your motherboard and firmly push it in place. Ensure that it is correctly seated otherwise the motherboard will be difficult to install and not align correctly with the stand-offs.

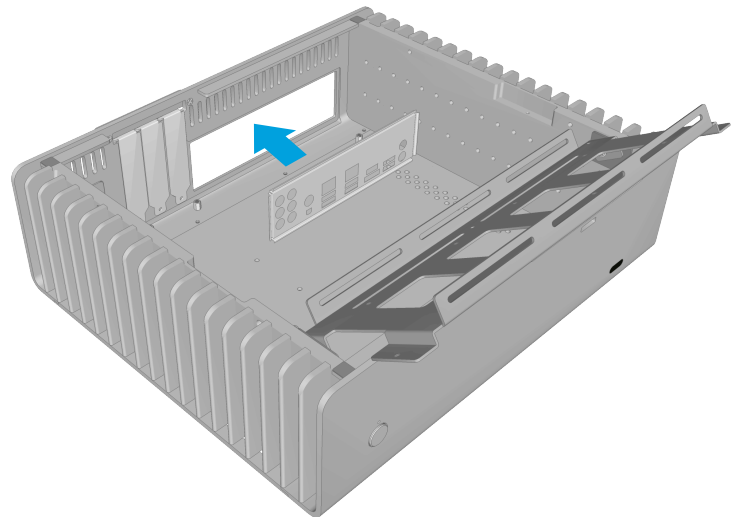

## Fit the CPU Cooler Mounting Nuts

The 4 CPU cooler mounting nuts supplied with your case must be fitted to the motherboard prior to installing it inside the case as they will be required later on in the assembly to secure the CPU cooler assembly. The nuts are held in place by adhesive pads which are supplied in a pack of 4 (there is a spare pack should you wish to change your motherboard in future). Affix the adhesive pads to the CPU nuts in preparation for fixing them to the motherboard.

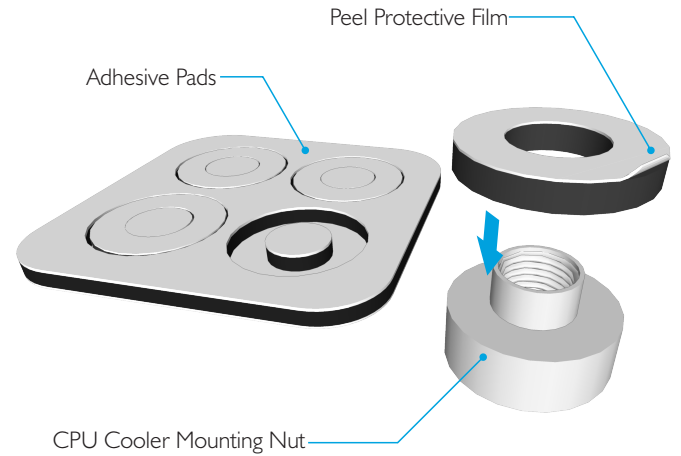
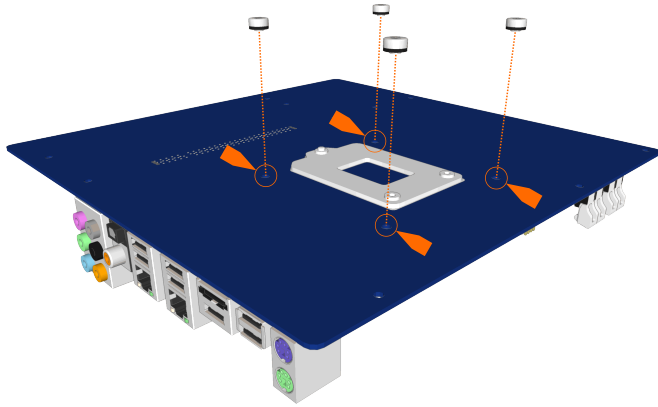

With the motherboard turned upside down, locate the CPU cooler mounting holes. The hole position will vary depending on the brand and model of CPU. Peel the protective film from the adhesive pads and stick the nuts to the underside of the motherboard ensuring they correctly align with the holes. The slightly raised rim of the nut should fit through the motherboard CPU mounting holes.

## Installing the Motherboard

Carefully lower the motherboard into the case, with the I/O port side leading so that the ports can fit into the I/O shield.

When the motherboard is correctly in position, secure it to the case stand-offs using the screws provided. Ensure that all the holes correctly align with the stand-offs before fully tightening the screws. Also ensure that you have installed the correct stand-off locations.

The CPU and RAM can now be installed on the motherboard.

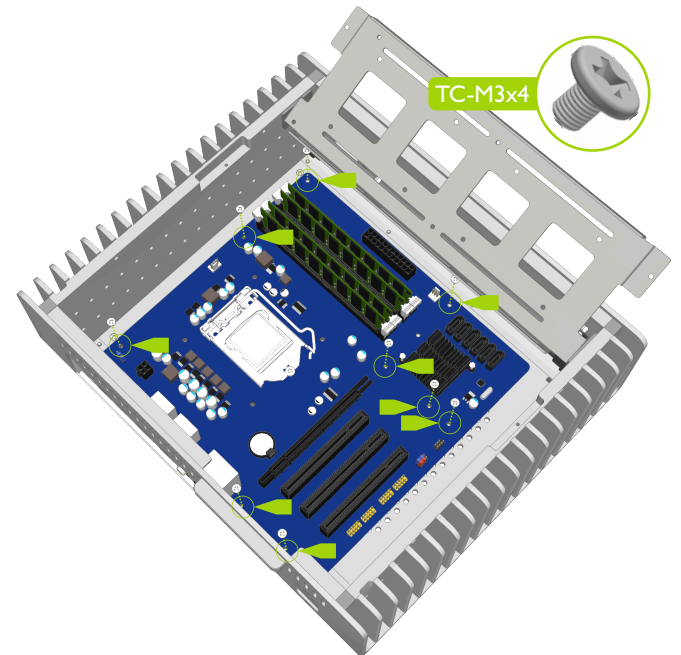

## CPU Cooler Assembly

The passive CPU cooler assembly comprises of 3 main parts. The CPU mounts which fix the heatpipes to the CPU & motherboard, the heatsink connector blocks that fix the heatpipes to the case side panel (heatsink), and the heatpipes that transfer the heat from the CPU to heatsink. Note that the heatpipes are numbered in the plastic sleeves, 1 - 4 to assist with identifying them.

The use of thermal paste is ESSENTIAL to ensure efficient heat transfer and should be applied to ALL the surfaces indicated below.

We recommend first trying the assembly without applying thermal paste. This will allow you to test and adjust the alignment without making a mess with thermal paste. Once you have a good approximation of the alignment, apply thermal paste initially between the lower CPU mount and heatpipes, then lock the heatpipes between the upper and lower CPU mounts using the 4 HEX screws. With this assembled, you can now remove it from the case and apply thermal paste to the CPU and heatsink contact side of the heatpipes.

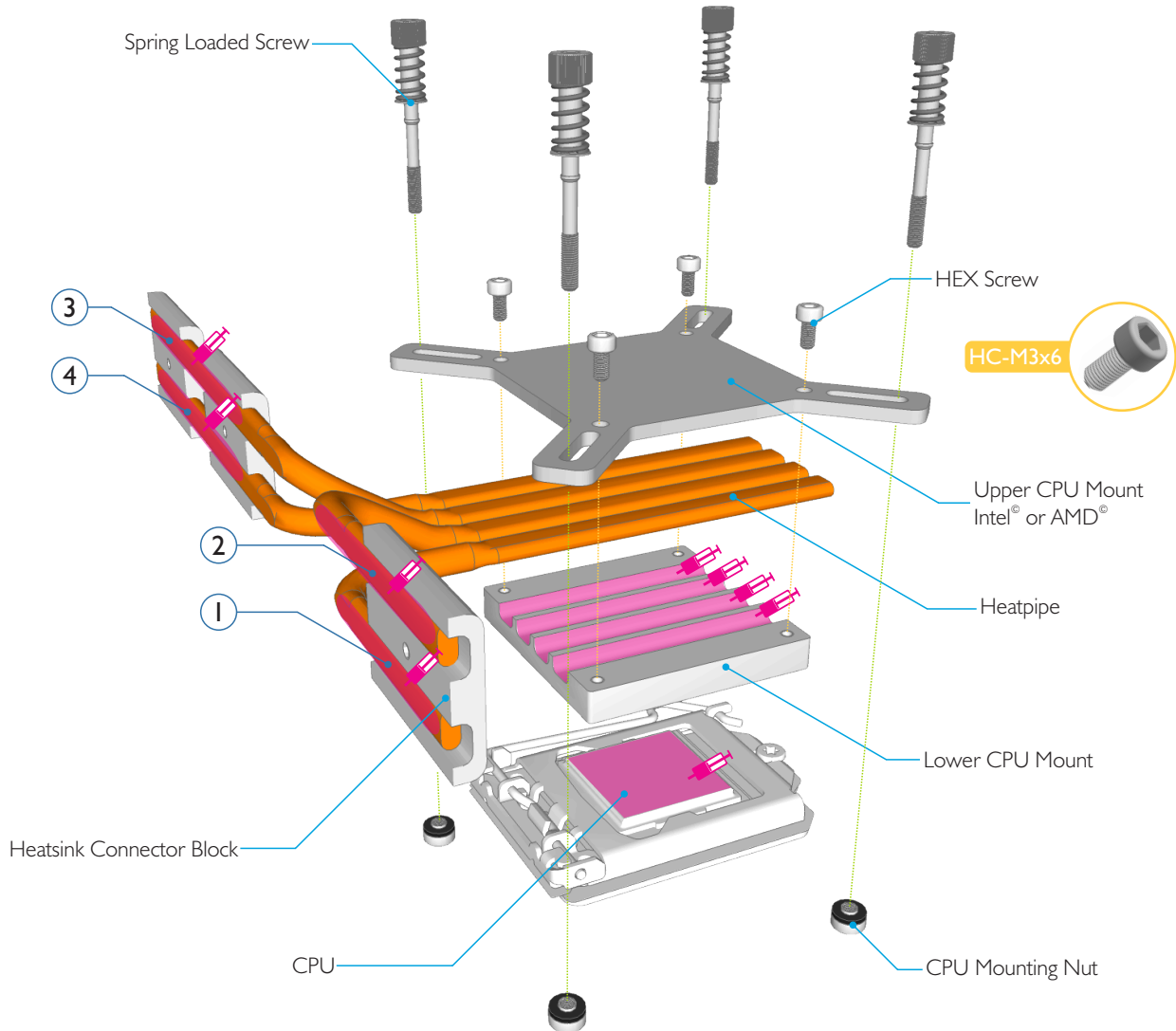

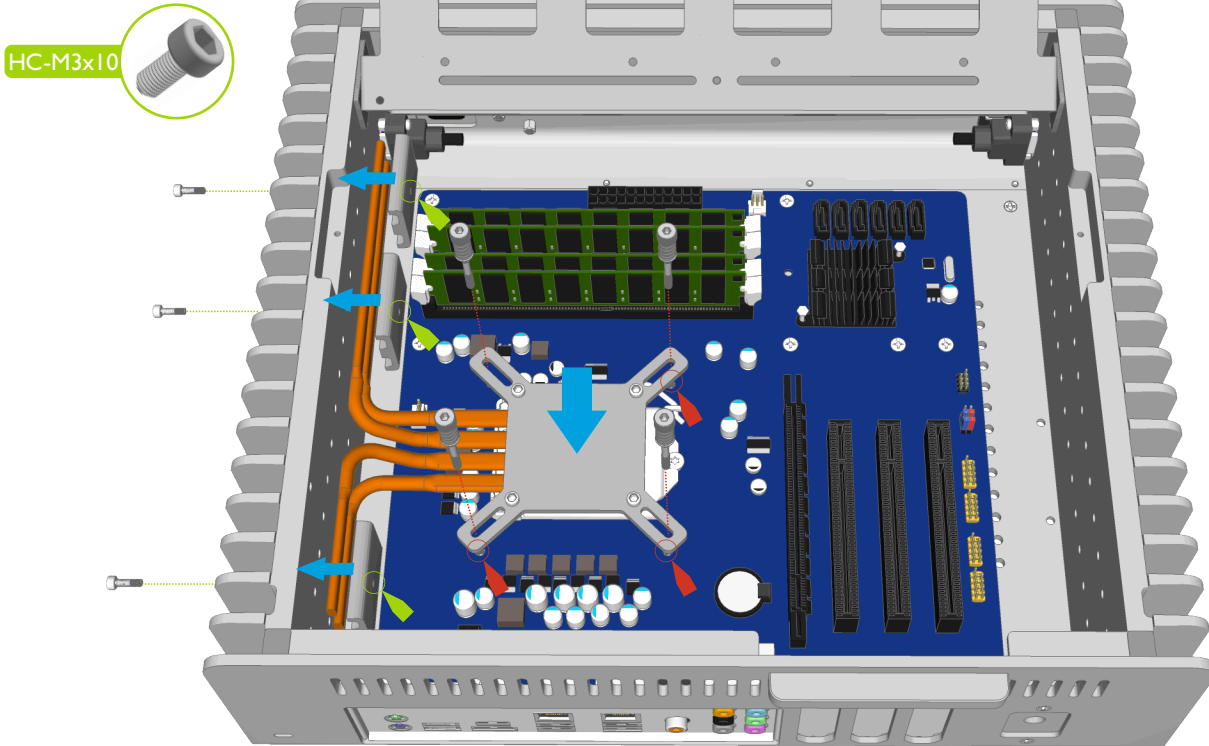

**Warning! Do not forget to use thermal paste, as this will result in poor heat transfer and potential CPU damage.**

Carefully lower the heatpipe/CPU mount assembly into the case and place it onto the CPU, ensuring the heatpipes only make contact with the heatsink once the assembly is resting centrally on the CPU. Fit the 4 spring loaded screws to the motherboard (into the CPU mounting nuts), but do not fully tighten yet.

Secure the heatpipes to the heatsink using the 3 connector blocks, which are screwed from the outside of the case (between the fins). If any fine adjustment is required, you can loosen the 4 HEX screws on the CPU mount which will allow the heatpipes to slide.

Once you are satisfied with the alignment of the full assembly, you can fully tighten all the screws. The spring loaded screws should not be over tightened, and only require 4-5 turns from the point the spring start to compress.



## Install / Connect the Power Button, PSU, Optional IR & Other Cables

With the motherboard and CPU cooler installed, you can now connect the PSU and any other internal connections such as the SATA cables in perpetration for installing the drives. For more details on installing the PSU and Optical IR, see the user guides supplied with those accessories.

Connect the front USB ports and the power button / light PCB to the motherboard, see diagram on next page for wiring details. The case is fitted with USB3.0 ports which require an internal USB3.0 connector on the motherboard. If your motherboard does not have an internal USB3.0 header, it is still possible to connect to the older USB2.0 header with a converter cable (not supplied with the case).

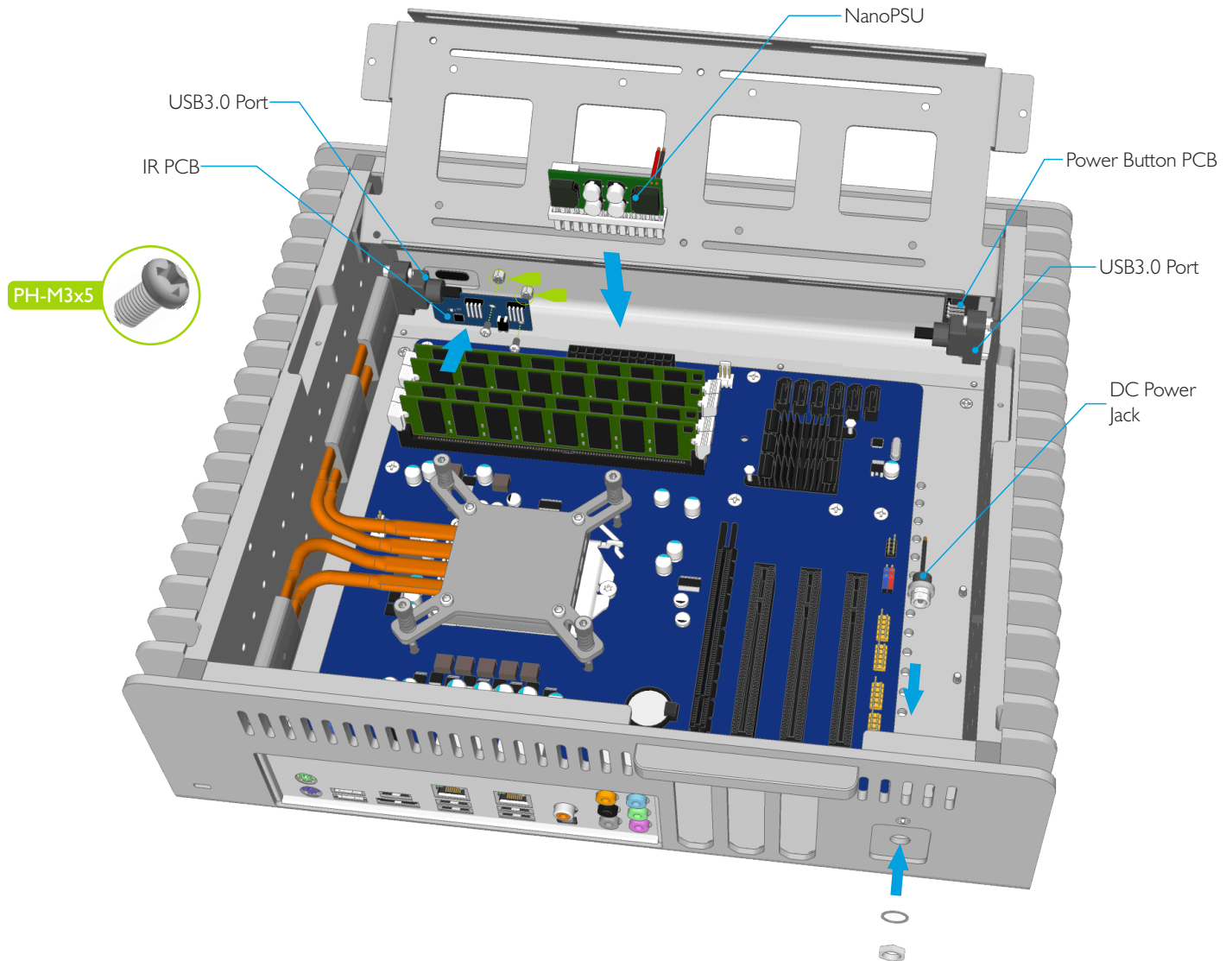

Motherboard pinout and cable colours shown are for illustrative purposes only, actual layout and markings will vary. Please check your motherboard user guide for full details and information.

When connecting the power LED, ensure correct polarity otherwise the light will not function.

If your motherboard does not have an internal USB3.0 header, it is still possible to connect to the USB2.0 header using a converter cable sold separately. Using this converter will make the front USB ports 2.0 compatible.

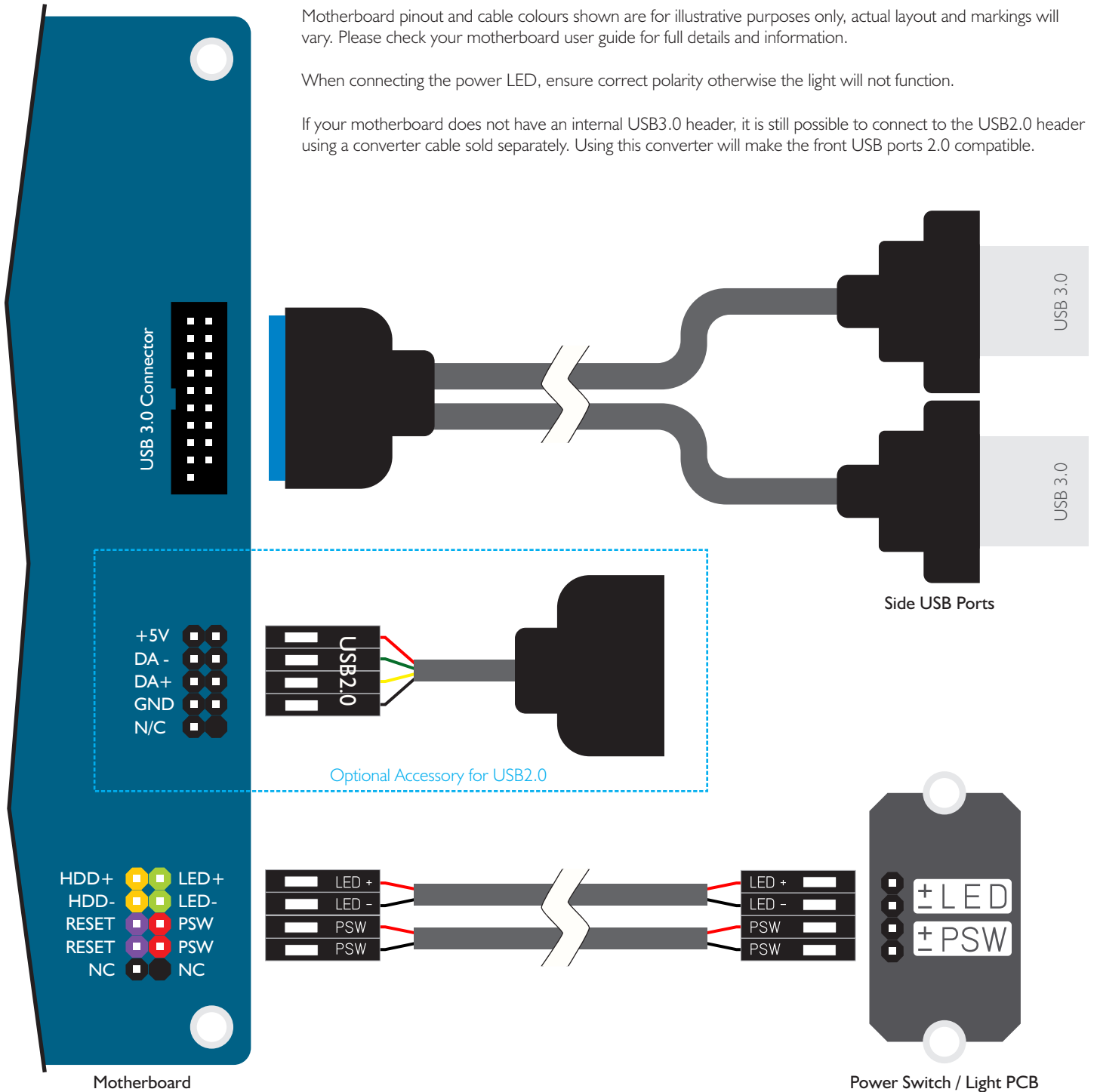

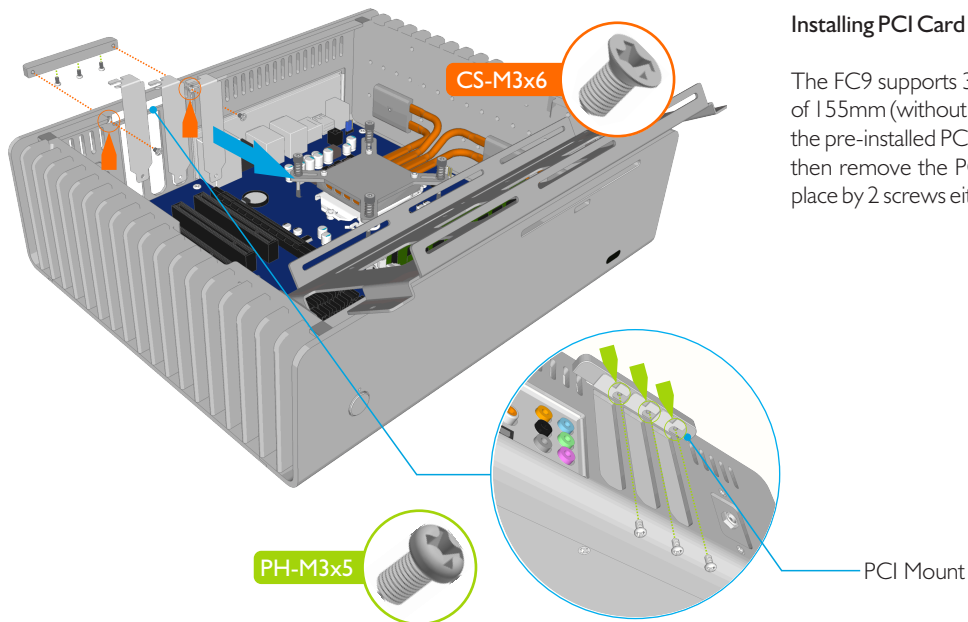

### Installing PCI Card (Optional)

The FC9 supports 3 low profile expansion cards with a maximum length of 155mm (without removing the drive tray). To install a card, first remove the pre-installed PCI blanking plates by unscrewing it from the PCI mount, then remove the PCI mount from the back of the case. It is secured in place by 2 screws either side accessible from the inside of the case.

Fit the expansion card to case by carefully aligning it with the opening and ensuring the lower side of the card bracket firstly slots in the gap between the motherboard and case. Once the cards are in place, replace the PCI mount then secure them to the PCI mount using the screws provided.

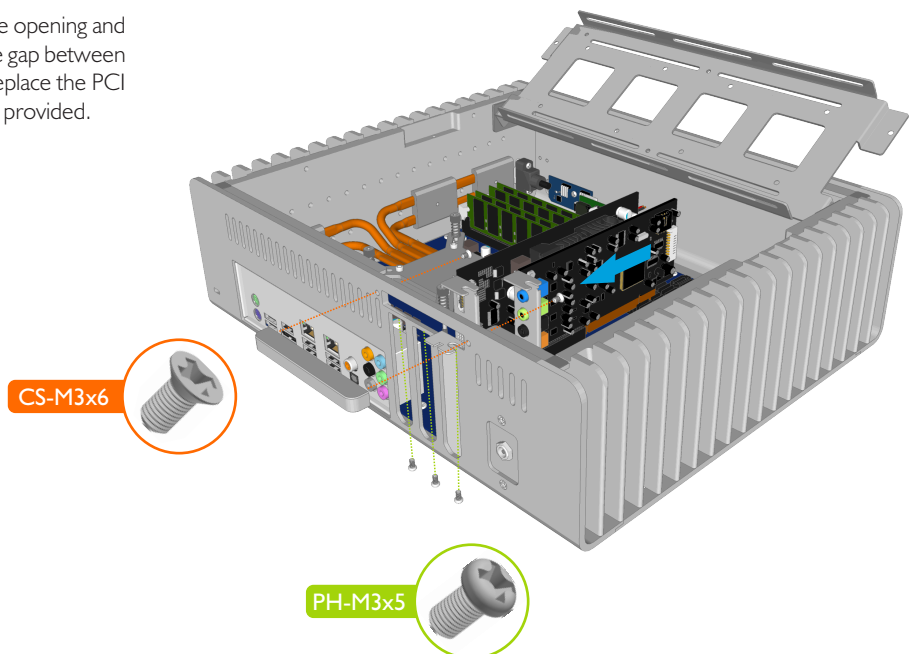

## Optical Drive Preparation

The OPTICAL version of the FC9, includes a drive mounting bracket which must be fitted to the drive prior to installing it onto the drive tray.

Secure the optical drive to the drive bracket using the 4 x 2mm screws supplied. The drive should be pushed as far forward as possible without activating the eject button before tightening the screws. If the screws meet any resistance (from internal components of the optical drive), do NOT tighten that screw any further, it could damage the mechanism. Once secured to the bracket, test the eject button can function correctly. Depending on the eject button position and height, a rubber pad might need to be affixed between eject bar and drive eject button. The pads can either be applied directly to the drives eject button, or to the opposite side of the eject button, or both sides, whichever gives the best result.

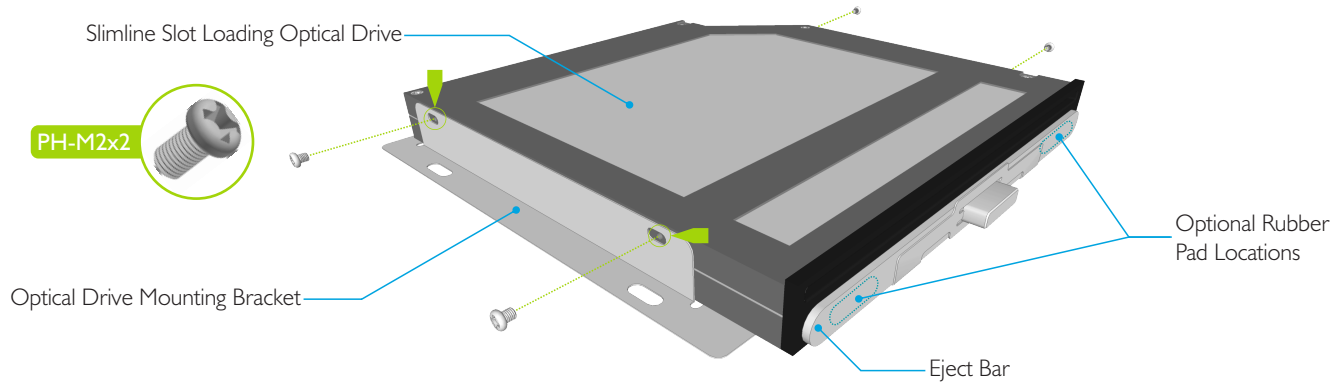

## Bottom Panel Drive Options

If you are using a Mini-ITX motherboard, there is also room to fit hard drives to the bottom panel of the case. Drives are secured in place through the pre-drilled holes in the bottom panel in the locations show. Screws should be attached through the bottom of the case and into the drive. Optional rubber pads can be used to raise the drive off the bottom panel, reducing vibration and improving airflow.

These drive locations should be used as a secondary option and only if there is no more room on the drive tray. Fitting drives to the bottom panel can reduce airflow as the lower vents are blocked, and this should be taken into account if using high TDP components.

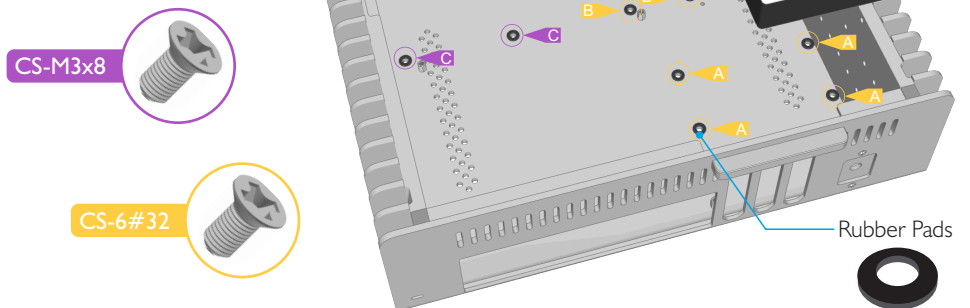

## Fitting Drives to the Lower Side of the Drive Tray

The lower side of the drive tray can accommodate a maximum of 1 x 3.5" drive or 2 x 2.5" drives.

The 3.5" mounting uses slots instead of fixed holes, to allow the drive to be fitted anywhere along the tray and with different orientations. The drive is secured to the tray from the side using thumbscrews which fit through the slots and into the side mounting holes of the drives. The 3.5" drive should only be fitted after all other drives are mounted to the tray.

If you prefer to use the lower side of the tray for 2.5" drives, they are secured to the drive tray using 4 screws per drive as shown below.

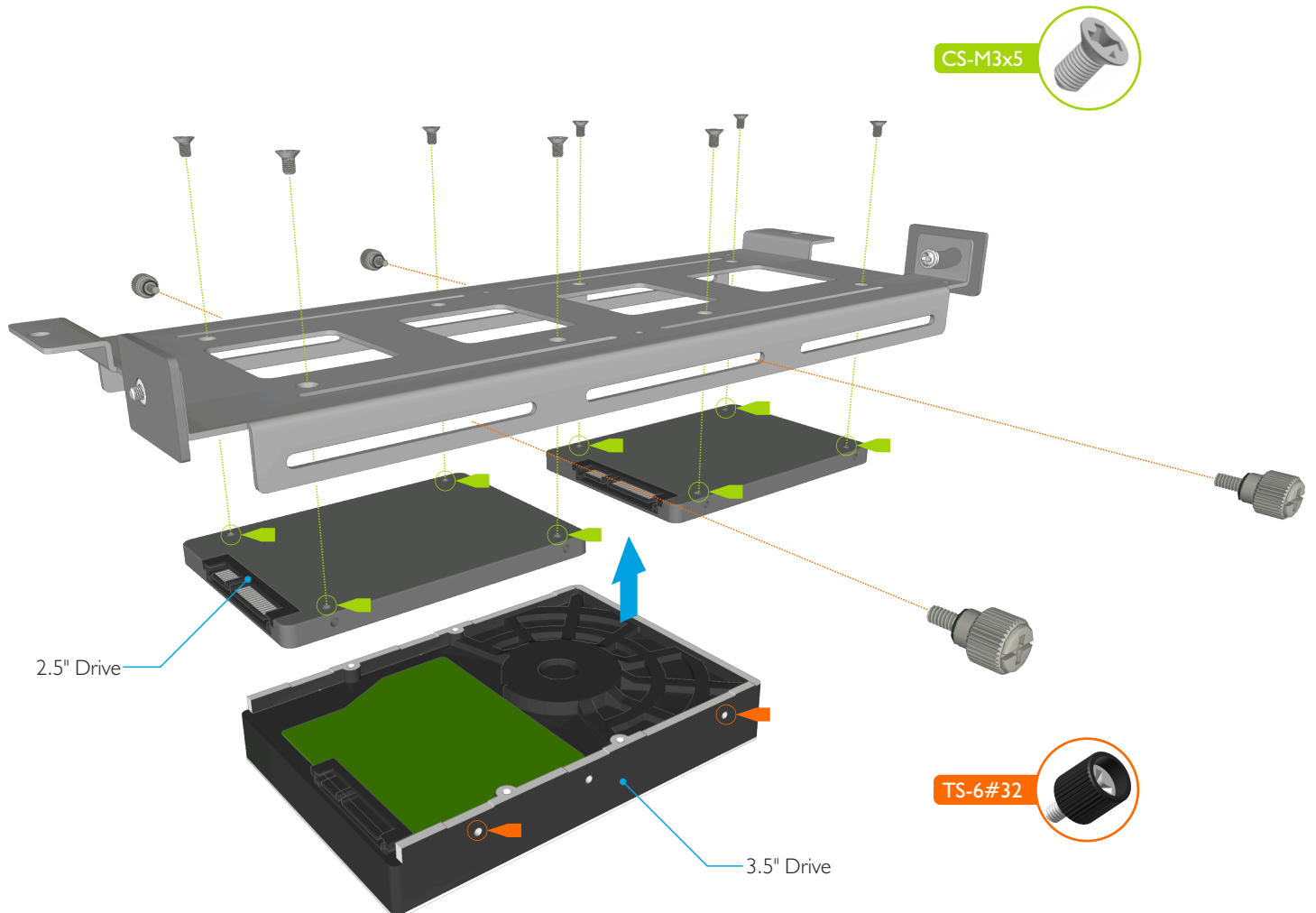

## Fitting Drives to the Upper Side of the Drive Tray

The upper side of the drive tray can accommodate a maximum of 3 x 2.5" drives or if you have the optical version of the FC9, 1 x 2.5" drive + 1 slimline optical drive. As with the 3.5" mounting, the upper 2.5" drives use slots instead of fixed holes, to allow the drive to be fitted anywhere along the tray. The drives are secured to the tray from below using 4 screws per drive.

If you have the OPTICAL version of the FC9, secure the optical drive to the drive tray with the 4 screws as shown, but **DO NOT** fully tighten the screws. Only after you have closed the drive tray back into the case should these screws be tightened as you will need to adjust the position of the drive to line up with the front of the case.

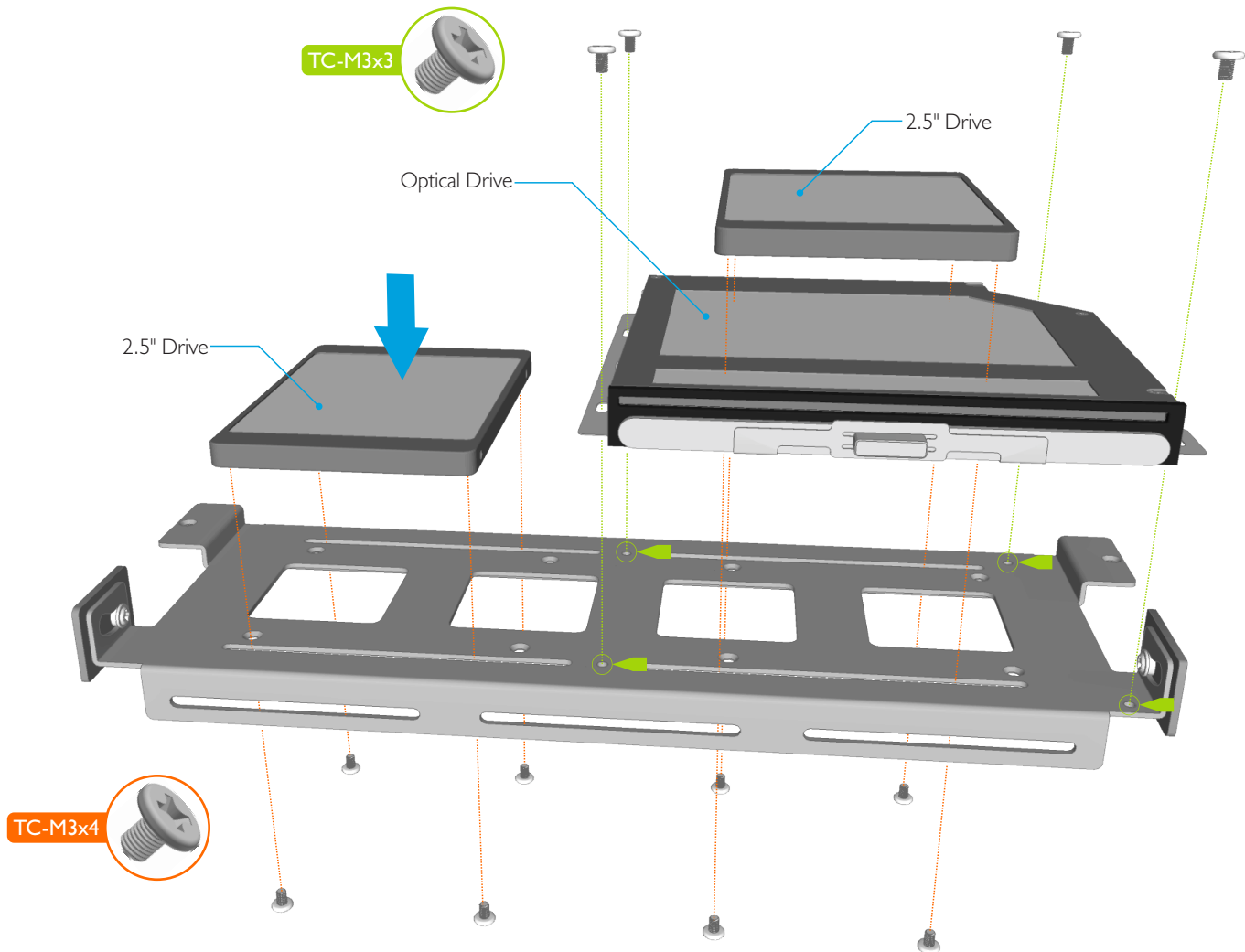

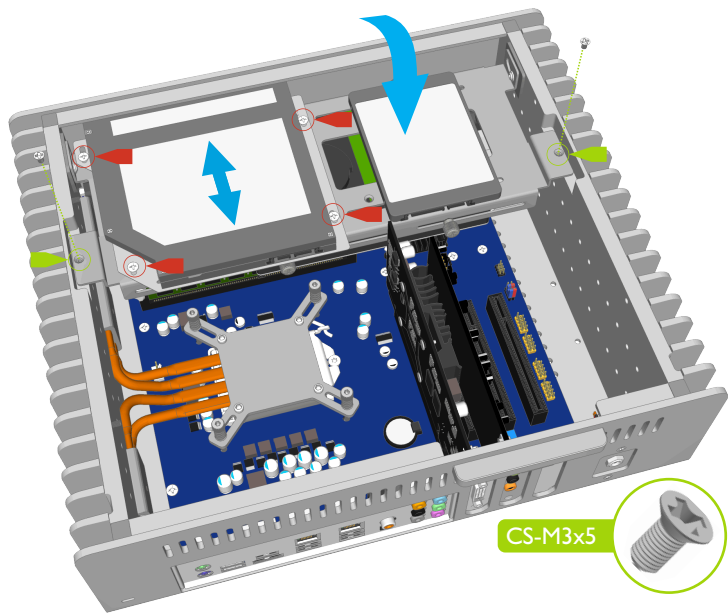

### Close and Secure the Drive Tray

With all the drives now fitted to the tray, return it to the original position and secure it in place with a single screw each side of the tray. Power and Data cables can now be connected to the drives.

### Adjusting the Optical Drive

Adjust the position of the optical drive so it's aligned with the inside front of the case and the eject button protrudes about 1mm out from the front of the case.

Test that the button operates correctly by listening/feeling for the button 'click' when pressing the eject button.

Once the correct position has been found, tighten the 4 screws to secure the optical drive in place.

### Replace the Top Panel

With all the components installed, the top panel can now be replaced. Prior to doing this, ensure that all cables are connected and all components are securely fitted. Secure the top panel in place using 4 screws, 2 from either side of the case, between the heatsink fins.

### Connect Power & Other Cables

With the case now fully assembled, all that remains is to connect the power and other cables.

When choosing a suitable place to position your case, please consider an area with adequate air flow and a moderate room temperature, out of direct sunlight.

